

SAFETY FIRST
ALWAYS KEEP THE GUN POINTED IN A SAFE DIRECTION
ALWAYS KEEP YOUR FINGER OFF THE TRIGGER UNTIL READY TO SHOOT
ALWAYS KEEP THE GUN UNLOADED UNTIL READY TO USE

PSR™ DOVETAIL PRODUCT MANUAL

PARTS LIST

1	RING BASE	× 2
2	CAP	× 2
3	CLAMP	× 2
4	M6×30 H5 SCREW	× 2
5	M4×10 T15 SCREW	× 8

REQUIRED TOOLS



TORQUE WRENCH / H5 & T15 BIT



H5 & T15 SCREWDRIVER

RELATED PRODUCTS

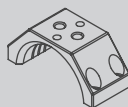

SCOPELINK™ ACCESSORY CAP

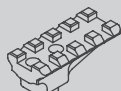

SLO005
 SCOPELINK™ RAIL H1 - 15MM

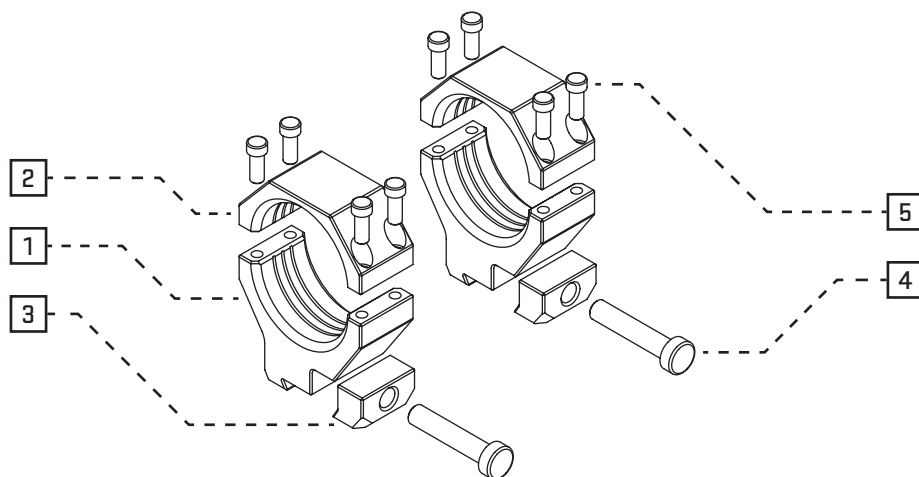

MAJOR FEATURES

- Scope rings compatible with 11mm and Kelbly dovetail rails
- CNC machined from single 7075-T651 aluminium billets
- Hardcoat anodizing / MIL-A-8625 Type III

INSTALLATION INSTRUCTIONS

1. Properly place the ring bases on the rail according to its type (FIG.A).
2. While keeping the bases in position, attach the clamps with M6×30 H5 screws applying a slight torque.
3. Tighten the clamping screws to the following torque value range: **3.5 - 4Nm [31 - 35.4 in-lb] (never exceed).**
4. Place the scope into the rings then attach the caps and start M4×10 T15 screws into the bases as shown (FIG.B).
5. Check for a comfortable eye relief and level the scope.
6. Make sure the gaps on either side of the clamp are kept even (FIG.C) then tighten the caps to the final torque value suggested by the scope manufacturer, **never exceed 3Nm [26.5 in-lb].**

FIGURE A

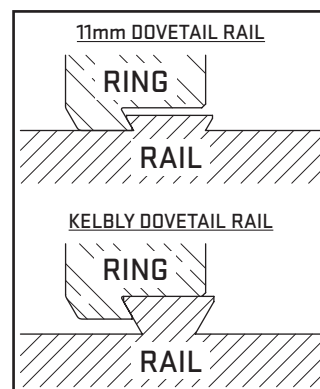

FIGURE B

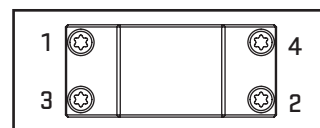
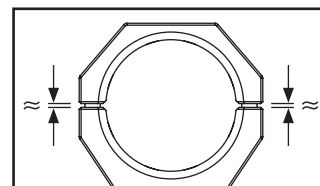

FIGURE C



ATTENTION

NEVER APPLY THREADLOCKER TO THE SCREWS
 PERIODICALLY CHECK SCREWS TIGHTENING

AUDERE SRL

CONTACTS

THANKS FOR YOUR PURCHASE

STRADA DEGLI ANGARIARI, 25
 47891 ROVERETA - RSM

TEL +378.0549.963180
 MAIL info@audere.sm

VISIT US AT
WWW.AUDERE.SM

